

## INSTALLATION AND SETUP GUIDE

### INTRODUCTION

The 5800RP RF Repeater Module consists of an RF receiver and a transmitter and is intended to extend the range of 5800 series RF devices by 200 feet (nominal).

The 5800RP receives alarm, status, and control messages from 5800 series devices, and forwards these messages to control panel connected receivers such as the 5881EN, 5883, 6128RF, 6150RF, and LYNX controls. The control then responds accordingly (arm/disarm the system, initiate an alarm, etc.).

The 5800RP also transmits its own status including tamper, AC loss and RF jam detect via a unique serial number. Status is sent whenever a change occurs or as part of a supervisory check-in message sent approximately once an hour.

The 5800RP contains a rechargeable battery that provides up to 6 hours of standby operation after primary power is lost.

The 5800RP features a Spatial Diversity system that virtually eliminates the possibility of "Nulls" and "Dead Spots" within the coverage area.

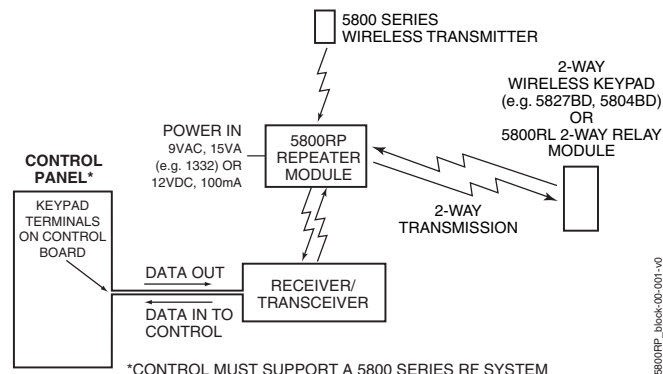

Figure 1.

### Wireless System Overview using 5800RP Repeater Module

### INSTALLING THE 5800RP MODULE

Mount the 5800RP remotely in its own housing following the steps below, and avoid mounting the module with its antennas touching a metal surface.

**Check for RF Interference:** Before mounting permanently, use the red RF Interference LED to check for strong local radio frequency interference at the intended mounting location. If this LED is continuously lit, the 5800RP module should be relocated.

**Removing the Cover:** Remove the 5800RP's cover by inserting and twisting a screwdriver blade in the slot at the center of the cover's lower edge. Note that removing the cover also places the 5800RP in the Go/No Go Test mode. This decreases its range during installation to insure an adequate margin during normal operation.

#### Mounting the Module

- For concealed wiring, route power wires through the rectangular opening at the rear of the base before mounting. For surface wiring entry, a thin breakaway area is provided along the base's right edge.
- Mount the module in the selected location. For greatest security, use all four mounting holes (two keyslot holes and two round holes) in the plastic base.
- Install each antenna in the respective right-hand terminal of the two terminal blocks at the upper edge of the 5800RP's circuit board, and tighten the screws to secure them.
- Affix the Summary of Connections label to the inside of the module's cover. Make sure the arrows and large 'plus sign' on the label line up with the corresponding posts in the cover.
- If applicable, set the Site ID by referring to the *Setting the Site ID* section on the next page.

#### Connecting the Power Supply

The 5800RP can be powered from either an AC or DC external power source connected to terminals 1 and 2 (see figure 2).

Power source ratings are as follows:

Type	Rating
AC	9VAC, 15VA (e.g., ADEMCO 1332)
DC	12VDC, 100 ma

- Connect the power supply to the 5800RP's terminals. Refer to Figure 2. These terminals are not polarized. The leads from DC supplies may be connected to either terminal.

**NOTE:** Use of power sources with higher or lower voltages may result in damage or failure to operate properly. Non-ADEMCO power supplies may have connectors installed. Remove the connectors prior to attempting to connect power supply to 5800RP.

#### Connecting the Battery

- Begin battery installation by attaching an adhesive backed hook and loop fastener strip (supplied) to the Summary of Connections label in the cover. Place the strip within the large box drawing labeled 'PLACE BATTERY HERE'. Refer to Figure 2.
- Attach another adhesive backed hook and loop fastener strip to the battery. Attach the battery to the cover by firmly pressing the two hook and loop fastener strips together. Make sure the battery is positioned as shown in Figure 2.
- Plug the battery cable into the battery connector on the 5800RP PCB. Refer to Figure 2.

**CHARGING NOTE:** The battery must be allowed to charge at least 12 hours in order to reach its full capacity.

- Replace the cover on the 5800RP, being careful not to pinch the battery wires between the cover and case or any PCB components.

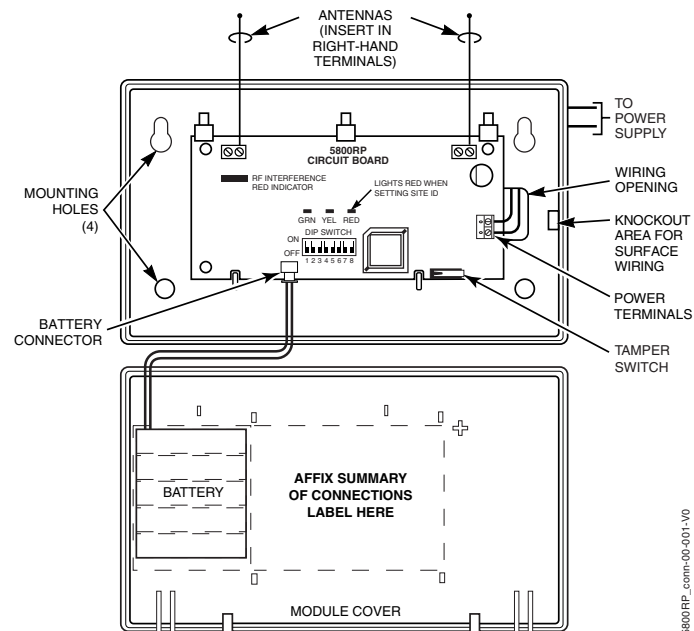

Figure 2.

### 5800RP Repeater Module Layout and Connections

## SETTING THE SITE ID

Some wireless devices (e.g., 5827, 5804BD) use a programmed house ID to help avoid communication conflicts with nearby installations. The 5800RP automatically passes all house ID information to the appropriate receiver.

Certain newer wireless devices, such as the 5883 and the 5839, use a "Site ID" instead of a House ID. The Site ID is a factory-assigned, unique serial number built into each 5883 transceiver and must be entered into each device that uses it. The Site ID provides many more combinations than a House ID, and therefore is less likely to have conflicts with nearby installations.

When using the 5800RP with wireless devices that use a Site ID, follow the steps below to enter a permanent copy of the Site ID in the 5800RP. This procedure assumes that all such devices have been successfully set-up and tested with the 5883, although they may not yet be mounted in their final locations.

1. Put the control (and the 5883) in the Go/No Go Test mode.
2. Remove the 5800RP's cover by inserting and twisting a screwdriver blade in the slot at the center of the cover's lower edge. Note that removing the cover also places the 5800RP in the Go/No Go Test mode. This decreases its range during installation to insure an adequate margin during normal operation.
3. Temporarily disconnect the power supply and battery from the 5800RP. Refer to Figure 2.
4. Place DIP switch 1 in the ON position.
5. Reconnect the power supply to the 5800RP. Observe that the red LED on the 5800RP turns on and remains on. This indicates that the 5800RP is ready to set the Site ID.
6. Push and release the tamper switch on the 5800RP. This causes a set-up request message to be sent to the 5883.
7. Observe that the red LED turns off, indicating that the Site ID has been saved in the 5800RP. If not, repeat the previous step until it does.

**NOTE:** If the tamper switch is not pushed for 1 minute or if DIP switch 1 is turned off, the red LED turns off. This indicates the 5800RP will no longer accept the Site ID.

8. Place DIP switch 1 in the OFF position.
9. Replace the cover on the 5800RP.
10. Take the control out of the Go/No Go Test mode.
11. If needed locate the other wireless devices in their final locations.
12. Test all wireless devices.

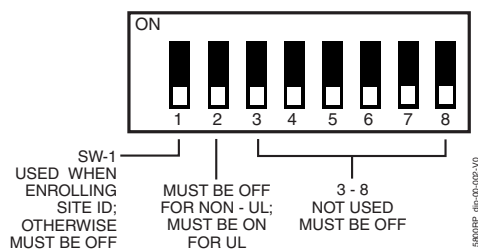

Figure 3 5800RP DIP Switch

## LED FUNCTIONS

LED	Activates Upon
Green	Normally on (lighted) when power (AC or battery) is present. Flickering indicates RF is being processed.
Yellow	Normally off. Blinks to indicate that an RF message is being sent by the 5800RP.
Red	Normally off. Turns on (lighted) when setting Site ID. See the <i>Setting the Site ID</i> section for details.
Red RF Interference	Lights when RF activity is present.

## PROGRAMMING AND OPERATIONAL NOTES

### Non-UL Installations

(DIP switch 2 must be OFF during normal operation)

1. Set DIP switch 2 to OFF.
2. If module supervision is desired, assign the 5800RP to a zone for sending check-in, low battery<sup>†</sup>, AC loss, and RF jam messages, and enroll its serial number. When prompted, toggle the tamper switch to enroll the serial number. The yellow LED should blink on when messages are sent.

Program the zone as follows:

Zone Type	Input Type	Loop
8 (24-hour aux)	3 (supervised RF)	1

- The 5800RP reports AC loss and RF jam conditions as "low battery" status, which is also displayed on the control's keypads. This prevents either condition from causing an alarm when the control is armed.
- The 5800RP will not repeat a message that has already been repeated.

### UL Installations

(DIP switch 2 must be ON during normal operation)

1. **Supervision:** Module supervision is required using the module's built-in serial numbers, which are enrolled in 4 zones as follows:
  - Assign the first serial number to a zone for sending low battery<sup>†</sup> and supervision check-in messages.
  - Assign the second serial number to 3 zones for sending tamper, AC loss, and RF jam messages.

When prompted, toggle the tamper switch to enroll the serial numbers.

Program the zones as follows:

First Serial Number			
Set DIP switch 2 to OFF, then enroll as follows:			
Zone	Zone Type	Input Type	Loop
Low Battery/ Check-in Zone	8 (24-hour aux)	3 - RF (supervised RF)	1
Second Serial Number			
Set DIP switch 2 to ON, then enroll as follows: (keep switch 2 in the ON position when enrolling is complete)			
Zone	Zone Type	Input Type	Loop
Tamper Zone	5 (trouble by day / alarm by night)	4 - UR (unsupervised RF)	1
AC Loss Zone	8 (24-hour aux)	4 - UR	2
RF Jam Zone	8 (24-hour aux)	4 - UR	3

For easy identification of these messages, program alpha descriptors at the control for each zone, using words such as "REPEATER LOW BATTERY, REPEATER AC LOSS, etc.

<sup>†</sup> If an actual low battery condition is reported, it takes up to 12 hours after AC power is restored for the low battery restore message to be sent (requires 12 hours for fully recharged battery).

2. **Power Supply:** Use a class 2 Listed Burglar Alarm power supply for UL installations.
3. **Control Panel's Current Drain Calculation:** In order to properly choose the correct backup battery capacity for systems using a 5800RP in UL installations, use the connected keypad's maximum alarm (sounder on) current rating, not the keypad's standby current rating, when calculating the control panel's total current drain. This is necessary because AC loss at the 5800RP causes the keypad to beep.

## SPECIFICATIONS

**Dimensions:** 7-3/8" W x 4-3/8" (10-7/8" w/antennas) H x 1-7/16" D.  
188mm W x 112mm H (277mm w/antennas) x 37mm D.

**Input Voltage:** 12VDC or 9VAC, 15VA (from separate power supply such as ADEMCO 1332).

**Current:** 80mA

**Battery Pack:** rechargeable, part number K0257

**Range:** 200ft (60m) nominal indoors from wireless devices (the actual range to be determined with the security system in the TEST mode).

### TO THE INSTALLER

Regular maintenance and inspection (at least annually) by the installer and frequent testing by the user are vital to continuous satisfactory operation of any alarm system.

The installer should assume the responsibility of developing and offering a regular maintenance program to the user, as well as acquainting the user with the proper operation and limitations of the alarm system and its component parts. Recommendations must be included for a specific program of frequent testing (at least weekly) to insure the system's operation at all times.

### RADIO FREQUENCY EMISSIONS

#### Federal Communications Commission (FCC) Part 15

#### FCC ID: CFS8DL5800RP

This device complies with Part 15 of the FCC Rules. Operation is subject to the following two conditions: (1) This device may not cause harmful interference, and (2) this device must accept any interference received, including interference that may cause undesired operation.

#### Industry Canada

This Class B digital apparatus complies with Canadian ICES-003.

Cet Appareil numérique de la classe B est conforme à la norme NMB-003 du Canada.

### FEDERAL COMMUNICATIONS COMMISSION (FCC) STATEMENT

This equipment has been tested to FCC requirements and has been found acceptable for use. The FCC requires the following statement for your information:

This equipment generates and uses radio frequency energy and if not installed and used properly, that is, in strict accordance with the manufacturer's instructions, may cause interference to radio and television reception. It has been type tested and found to comply with the limits for a Class B computing device in accordance with the specifications in Part 15 of FCC Rules, which are designed to provide reasonable protection against such interference in a residential installation. However, there is no guarantee that interference will not occur in a particular installation. If this equipment does cause interference to radio or television reception, which can be determined by turning the equipment off and on, the user is encouraged to try to correct the interference by one or more of the following measures:

- If using an indoor antenna, have a quality outdoor antenna installed.
- Reorient the receiving antenna until interference is reduced or eliminated.
- Move the radio or television receiver away from the receiver/control.
- Move the antenna leads away from any wire runs to the receiver/control.
- Plug the receiver/control into a different outlet so that it and the radio or television receiver are on different branch circuits.

If necessary, the user should consult the dealer or an experienced radio/television technician for additional suggestions. The user or installer may find the following booklet prepared by the Federal Communications Commission helpful:

"Interference Handbook"

This booklet is available from the U.S. Government Printing Office, Washington, DC 20402.

*The user shall not make any changes or modifications to the equipment unless authorized by the Installation Instructions or User's Manual. Unauthorized changes or modifications could void the user's authority to operate the equipment.*

## LIMITED WARRANTY

Honeywell International Inc., acting through its Security & Custom Electronics business ("Seller") 165 Eileen Way, Syosset, New York 11791, warrants its product(s) to be in conformance with its own plans and specifications and to be free from defects in materials and workmanship under normal use and service for 24 months from the date stamp control on the product(s) or, for product(s) not having a manufacturer's date stamp, for 12 months from date of original purchase unless the installation instructions or catalog sets forth a shorter period, in which case the shorter period shall apply. Seller's obligation shall be limited to repairing or replacing, at its option, free of charge for materials or labor, any product(s) which is proved not in compliance with Seller's specifications or proves defective in materials or workmanship under normal use and service. Seller shall have no obligation under this Limited Warranty or otherwise if the product(s) is altered or improperly repaired or serviced by anyone other than Honeywell factory service. For warranty service, return product(s) transportation prepaid, to Honeywell Factory Service, 165 Eileen Way, Syosset, New York 11791.

THERE ARE NO WARRANTIES, EXPRESS OR IMPLIED, OF MERCHANTABILITY, OR FITNESS FOR A PARTICULAR PURPOSE OR OTHERWISE, WHICH EXTEND BEYOND THE DESCRIPTION ON THE FACE HEREOF. IN NO CASE SHALL SELLER BE LIABLE TO ANYONE FOR ANY CONSEQUENTIAL OR INCIDENTAL DAMAGES FOR BREACH OF THIS OR ANY OTHER WARRANTY, EXPRESS OR IMPLIED, OR UPON ANY OTHER BASIS OF LIABILITY WHATSOEVER, EVEN IF THE LOSS OR DAMAGE IS CAUSED BY THE SELLER'S OWN NEGLIGENCE OR FAULT.

Seller does not represent that the product(s) it sells may not be compromised or circumvented; that the product(s) will prevent any personal injury or property loss by burglary, robbery, fire or otherwise; or that the product(s) will in all cases provide adequate warning or protection. Customer understands that a properly installed and maintained alarm system may only reduce the risk of a burglary, robbery, fire, or other events occurring without providing an alarm, but it is not insurance or a guarantee that such will not occur or that there will be no personal injury or property loss as a result. CONSEQUENTLY, SELLER SHALL HAVE NO LIABILITY FOR ANY PERSONAL INJURY, PROPERTY DAMAGE OR OTHER LOSS BASED ON A CLAIM THAT THE PRODUCT(S) FAILED TO GIVE WARNING. HOWEVER, IF SELLER IS HELD LIABLE, WHETHER DIRECTLY OR INDIRECTLY, FOR ANY LOSS OR DAMAGE ARISING UNDER THIS LIMITED WARRANTY OR OTHERWISE, REGARDLESS OF CAUSE OR ORIGIN, SELLER'S MAXIMUM LIABILITY SHALL NOT IN ANY CASE EXCEED THE PURCHASE PRICE OF THE PRODUCT(S), WHICH SHALL BE THE COMPLETE AND EXCLUSIVE REMEDY AGAINST SELLER.

This warranty replaces any previous warranties and is the only warranty made by Seller on this product(s). No increase or alteration, written or verbal, of the obligations of this Limited Warranty is authorized.

# Honeywell

165 Eileen Way, Syosset, New York 11791

Copyright © 2004 Honeywell International, Inc.

[www.honeywell.com/security](http://www.honeywell.com/security)



K0344 6/02 Rev. B